

Direction of air flow

850.00

65.00

400.00

UVAJ-500T6-01,
500mm Amalgam
lamp, Ozone, 4X

EBA-100-21U,
Amalgam ballast, 4X

Preliminary

Dimensions are in mm tolerance (Unless otherwise specified) x +/- 1.0	 1246 E. Lexington Ave. Pomona, CA 91766		
	UV reactor		
Proprietary & Confidential	SIZE A	FSCM NO	DWG NO REV 3
	SCALE N/A		SHEET 1 OF 2

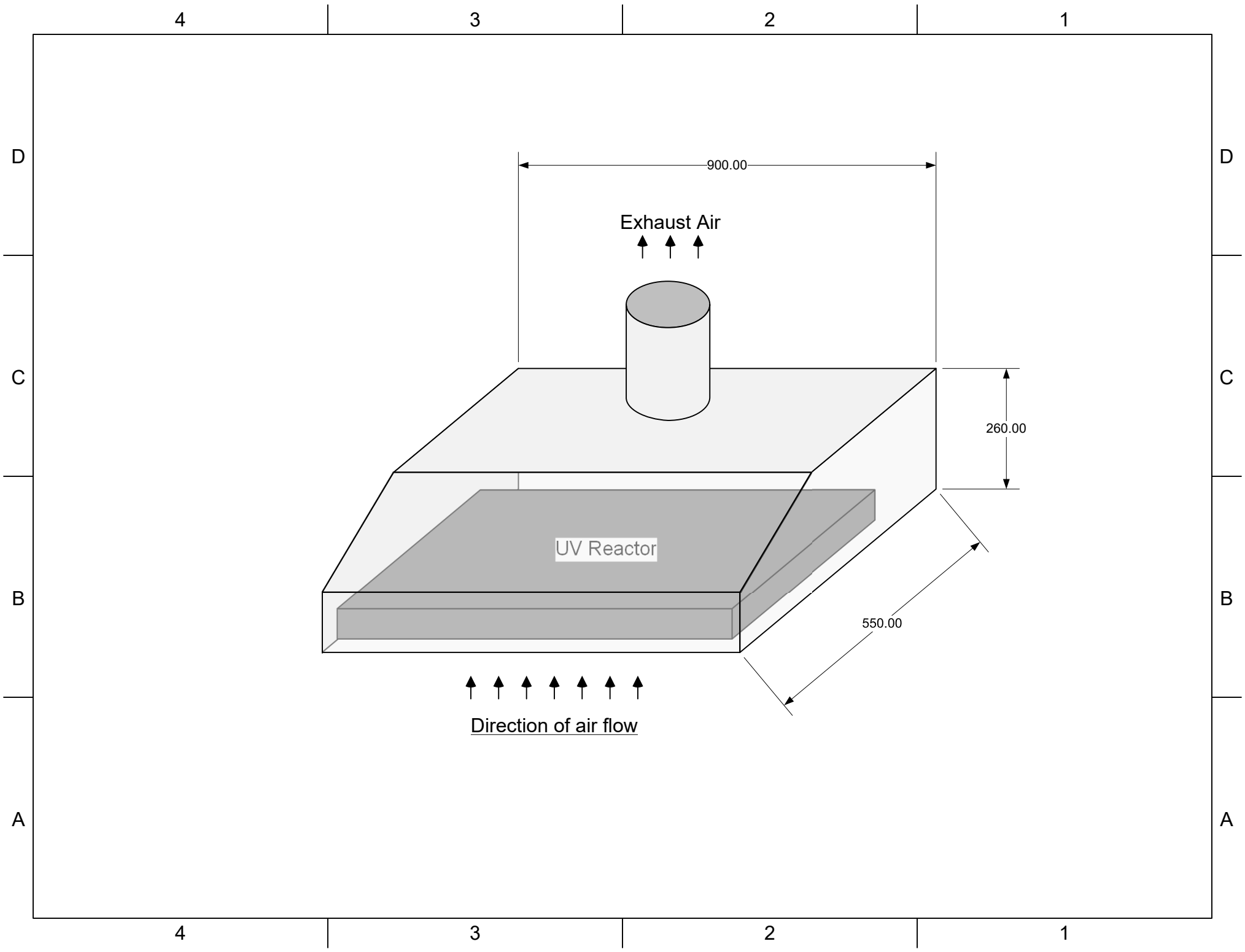

4

3

2

1

D

D

C

C

B

B

A

A

900.00

Exhaust Air

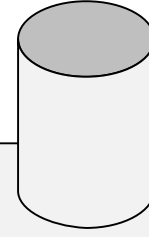

260.00

UV Reactor

550.00



Direction of air flow

4

3

2

1